

## 合金贴片电阻规格书-RM 系列

Approval Specification Metal Current Sensing Chip Resistors-Type *RM*

规格书

# SPECIFICATION

## 丽智电子（南通）有限公司

地址：江苏省南通市通州区康富路 789 号

Address: No. 789, Kang Fu Road Tongzhou District Nantong city Jiangsu province

Tel: 0086-0513-68856666

Fax: 0086-0513-68383688

## 合金贴片电阻规格书-RM 系列

### Approval Specification Metal Current Sensing Chip Resistors-Type RM

#### 1 范围 (scope) :

1.1 适用于本公司所生产的无铅、无卤之合金贴片电阻 RM 系列

This specification applies to metal current sensing chip resistors which meet requirements of Pb free and halogen free.

#### 2 产品料号 (part number) :

2512 1% 2W 10mΩ

RM2512FBR010GM

<u>RM</u>	<u>2512</u>	<u>F</u>	<u>B</u>	<u>R010</u>	<u>G</u>	<u>M</u>
类型(Type) RM: 合金贴片电阻 (Metal current sensing chip resistors)	尺寸(Size) 1206 2512	公差 Tolerance D=±0.5% F=±1% G=±2% J=±5%	额定功率 Rated Power 1= 1W B= 2W C=3W	阻值 Resistance value R002=2mΩ R010=10 mΩ 3L50=3.5mΩ	包装代码 Packing Code G= reel (卷装) V= bulk (散料) S= Double Standard Quantity (两倍卷盘标准包装量)	电极 terminal M=窄电极 Narrow terminal T=宽电极 Wide terminal

## 合金贴片电阻规格书-RM 系列



### Approval Specification Metal Current Sensing Chip Resistors-Type RM

#### 3 电阻本体字码标示(Marking on the Resistor's Body):

※  $\pm 0.5\%$ ,  $\pm 1\%$ ,  $\pm 2\%$ ,  $\pm 5\%$  的产品, 以四字码标示, 第一位字码 R 标示  $10^{-3}$ , 后三位表示阻值的有效数字, 第二位字码 R 表示阻值小数点。

※ 1206 1m $\Omega$  产品以二字码标示, 显示 01 两位有效数字

$\pm 0.5\%$ ,  $\pm 1\%$ ,  $\pm 2\%$ ,  $\pm 5\%$  tolerance product: the marking is 4 digits, The first letter 'R' denotes  $10^{-3}$ , The other three digitals declare resistance. The second letter 'R' mean point. (1206 1m Ohm products are marked with 2 digits, and 01 is a valid digit)

R010=10m $\Omega$	3R5m=3.5m $\Omega$	1206=1 m $\Omega$
		

#### 4 尺寸 (dimension) :

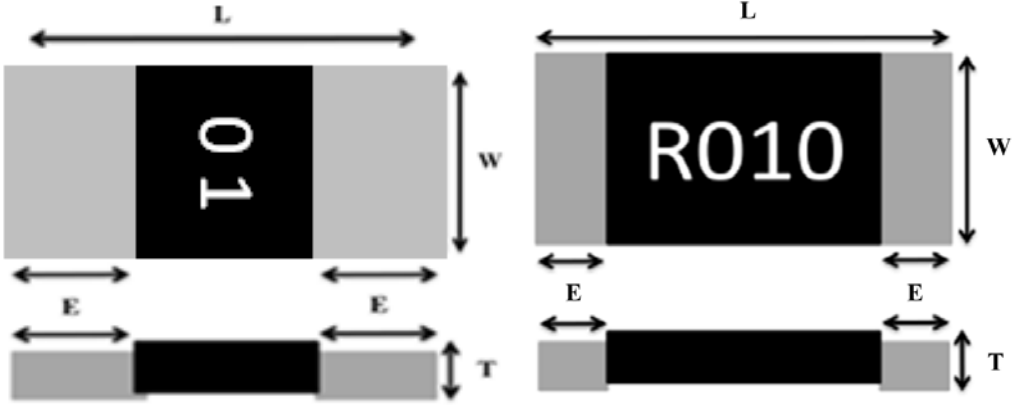
尺寸 dimension				
	单位 (unit) : mm			
型别 Type	L	W	T	E
RM1206*T (R=1m $\Omega$ )	3.2 $\pm$ 0.20	1.6 $\pm$ 0.20	0.9 $\pm$ 0.15	1.6 $\pm$ 0.25
RM1206*M (2-100m $\Omega$ )			0.70 $\pm$ 0.15	0.50 $\pm$ 0.30

## 合金贴片电阻规格书-RM 系列

### Approval Specification Metal Current Sensing Chip Resistors-Type RM

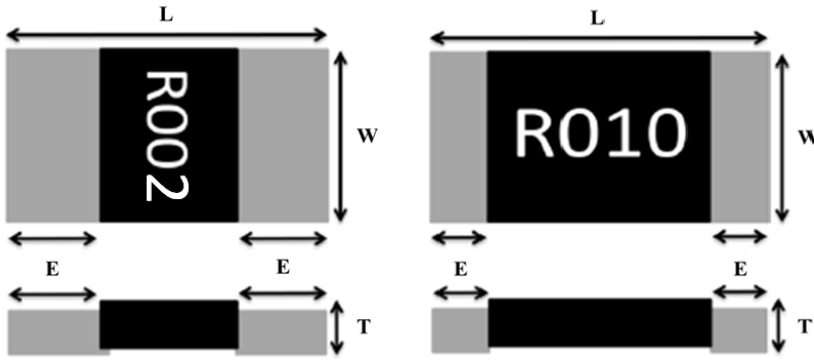
尺寸 dimension				
	单位 (unit) : mm			
型别 Type	L	W	T	E
RM2512*T (1-4 mR)	6.4±0.2	3.2±0.2	0.7±0.2	2.0±0.2
RM2512*M (3-300mR)	6.4±0.2	3.2±0.2	0.8±0.2	0.95±0.25

### 5 功率衰减曲线 ( Derating Curve ) :

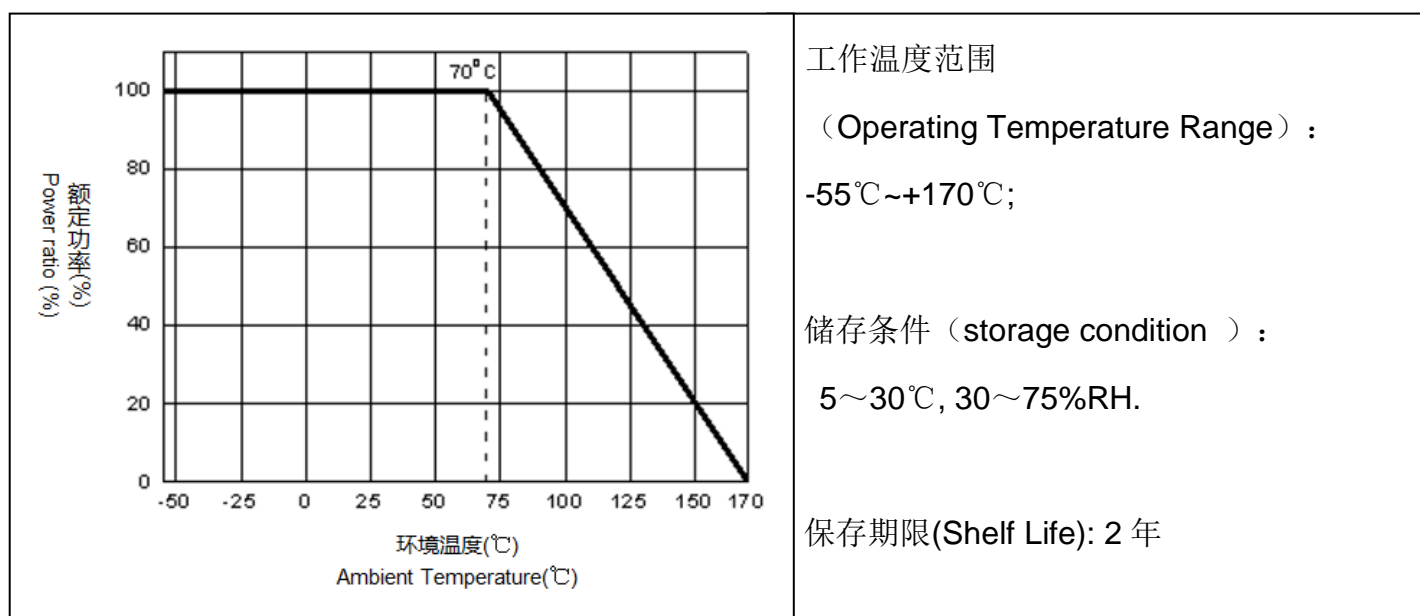

## 合金贴片电阻规格书-RM 系列

### Approval Specification Metal Current Sensing Chip Resistors-Type RM

#### 6 电阻结构 (Construction) :

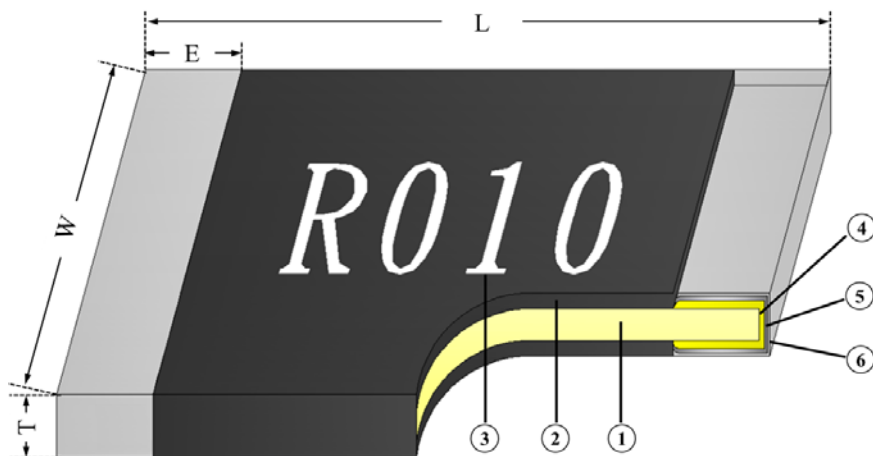

No.	结构 construction	主要材料 Major material
1	阻体 Resistive layer(Metal Alloy)	合金 Metal Alloy
2	保护层 Protective layer	环氧树脂 Epoxy
3	文字 Marking	环氧树脂 Epoxy
4	铜电极 Cu plating layer	铜 Cu
5	镍电极 Ni plating layer	镍 Ni
6	锡电极 Sn plating layer	锡 Sn

## 合金贴片电阻规格书-RM 系列

### Approval Specification Metal Current Sensing Chip Resistors-Type RM

#### 7 阻值范围及电气特性 (Resistance Range and Electrical Characteristics) :

型别 Type	额定功率 Rated Power	阻值范围 Resistance Range	温度特性TCR (ppm/°C)	最高额定电流(A) Max Rating Current (A)	最高过载电流(A) Max Overload Current(A)
		D(±0.5%)、F(±1%)、 G(±2%)、J(±5%)			
RM1206*T	1W	1mΩ	±50	31.62	70.71
RM1206*M		2mΩ~100mΩ	±50	22.36	50
RM2512*T	2W	1mΩ~4mΩ	±50	44.72	100
RM2512*M		3mΩ~300mΩ	±50	25.82	57.74
RM2512*T	3W	1mΩ~4mΩ	±50	54.77	122.47
RM2512*M		3mΩ~100mΩ	±50	31.62	70.71

#### 备注 (remark) :

※ 额定电流计算公式 (The rated current is calculated by the following formula) :

$$I = \sqrt{P/R}$$

I: 额定电流 (Rated current) (A)

P: 额定功率 (Rated Power) (W)

R: 电阻阻值 (Resistance) (Ω)

※ 如果计算出的电流超过此型别的最大工作电流, 则此型别的最大工作电流为此电阻的额定电流。

In case the value calculated by the formula exceed the maximum working current as above table, the maximum working current shall be regarded as rated current.

## 合金贴片电阻规格书-RM 系列

### Approval Specification Metal Current Sensing Chip Resistors-Type RM

#### 8 性能(Performance Specifications)

内容 Item	测试方法 Test Methods	测试条件 Test Conditions	规格 Specification
短时间过负荷 Short-time overload	JIS-C5201-1 4.13	加载 5 倍的额定功率，时间 5 秒后测量试验前后的阻值变化率。 Applied 5.0 times of rated power for 5 second. Measure the variation of resistance. $\Delta R\% = (R_2 - R_1) / R_1 * 100$ R1 = 试验前阻值(resistance before test) R2 = 试验后阻值(resistance after test)	$\cong \pm 0.5\%$
温度系数 Temperature Coefficient	JIS-C5201-1 4.8	$TCR = (R - R_0) / (t - t_0) R_0 \times 10^6$ (ppm) R <sub>0</sub> 电阻在室温下的阻值(resistance at room temperature) R 电阻在 125℃ 下的阻值(resistance at 125℃) t <sub>0</sub> 室温(room temperature) t 测试温度 125℃ (test temperature 125℃)	参照规格表 As Spec.
耐湿特性 Biased Humidity	MIL-STD-202 METHOD 103	加载 10%额定功率，85℃/85%RH，持续通电 1000H，试验结束 24±4 小时后进行测试 1000 hours Note: 10% Rated power at 85℃, RH:85%, 1000Hrs, Measurement at 24hrs after test conclusion.	$\cong \pm 0.5\%$
温度循环 Temperature cycling	JESD22 Method JA-104	-55℃&+125℃，温度保留 30min，循环 1000 次，试验结束 24±4 小时后量测试验前后阻值变化率。 1000Cycle (-55℃ to 125℃) , Temperature retention for 30 minutes, Measurement at 24hrs after test conclusion.	$\cong \pm 0.5\%$

## 合金贴片电阻规格书-RM 系列

### Approval Specification Metal Current Sensing Chip Resistors-Type RM

内容 Item	测试方法 Test Methods	测试条件 Test Conditions	规格 Specification
Load Life 负荷寿命	JIS-C5201-1 4.25	电阻放入恒温箱中，温度 $70\pm 2^{\circ}\text{C}$ ，通电额定电流 1.5 小时，断电 0.5 小时；重复通断电至试验时间 1000 +48/-0 小时。量测试验前后阻值变化率。 Put the specimen in a chamber at $70\pm 2^{\circ}\text{C}$ temperature, and applied rated Current for 1.5H and rested for 0.5H repeatedly till total test time is 1000 +48/-0 .. Measure the variation of resistance.	$\cong \pm 1.0\%$
高温储存 High Temperature Exposure (Storage)	MIL-STD-202 Method 108	$125^{\circ}\text{C}$ 下放置 1000H，试验结束 $24\pm 4$ 小时后量测试验前后阻值变化率。 1000 hrs. @ $T=125^{\circ}\text{C}$ . Measure the variation of resistance at $24\pm 4$ hours after test conclusion.	$\cong \pm 1.0\%$
抗焊锡热 Resistance to soldering heat	JIS-C5201-1 4.18	沾助焊剂后浸入锡炉，锡炉温度 $260\pm 5^{\circ}\text{C}$ ，时间 $10\pm 1$ 秒，测量试验前后的阻值变化率。 Dip the terminal in a flux and then dip into a soldering bath at $260\pm 5^{\circ}\text{C}$ for $10\pm 1$ sec. Measure the variation of resistance.	$\cong \pm 0.5\%$
焊锡性 Solderability	JIS-C-5201-1 4.17	沾助焊剂后浸入锡炉，锡炉温度 $245\pm 5^{\circ}\text{C}$ ，时间 $3\pm 1$ 秒 Dip the terminal in a flux and then dip into a soldering bath at $245\pm 5^{\circ}\text{C}$ for $3\pm 1$ sec.	最少 95%面积上锡 (Min 95% coverage)
端子弯曲 Board Flex	JIS-C5201-1 4.33	弯曲 2mm，10 秒，量测试验前后阻值变化率。 Bending once for 2mm, 10 seconds.	$\cong \pm 0.5\%$
端子强度 Terminal Strength	JIS-C5201-1 4.32	应用 5N，时间 $10\pm 1$ 秒 Applied a 5N for $10\pm 1$ seconds.	$\cong \pm 1\%$ 无破损 No broken
ESD 试验 ESD test	IEC61000-4-2	加载规定静电电压 2KV.2 次/间隔 1 秒， Other:2KV, 2times/1s	$\cong \pm 1\%$

## 合金贴片电阻规格书-RM 系列

### Approval Specification Metal Current Sensing Chip Resistors-Type RM

#### 9 包装规格 (Tapping Specification)

##### a) 卷盘尺寸 (reel dimension)

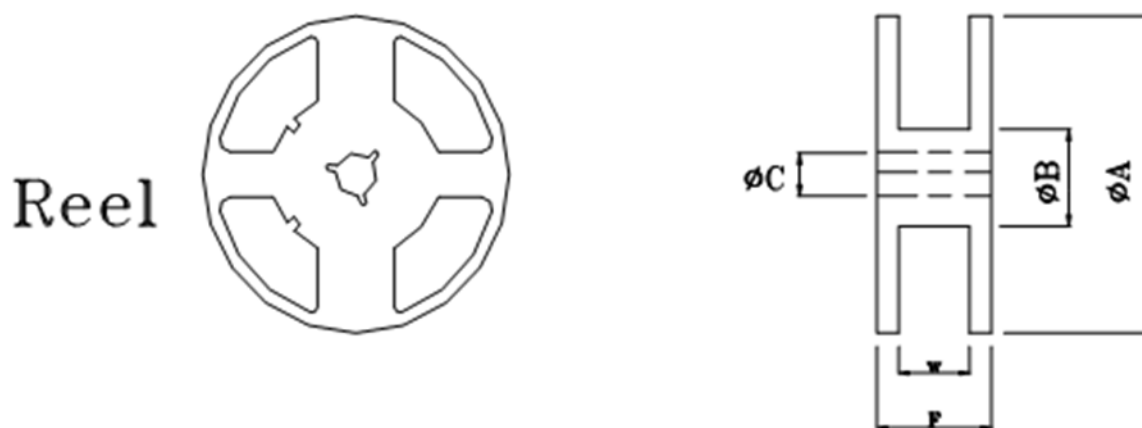

尺寸 Dimensions		A	B	C	F	W
RM1206	mm	178±2.00	60.00±1.00	13.50±0.50	11.40±0.10	9.00±0.30
	Inch	7.008±0.079	2.362±0.039	0.531±0.020	0.449±0.039	0.354±0.012
RM2512	mm	178±2.00	60.00±1.00	13.50±0.50	15.40±1.00	13.00±0.3
	Inch	7.008±0.079	2.362±0.039	0.531±0.020	0.606±0.039	0.512±0.012

备注 (Remark) : (1) 2512 每卷 4,000 pcs

2512 Quantity per Reel 4,000 pcs/Reel

(2) 1206 每卷 5,000pcs

1206 Quantity per Reel 5,000 pcs/Reel

## 合金贴片电阻规格书-RM 系列

### Approval Specification Metal Current Sensing Chip Resistors-Type RM

#### b) 包装尺寸 (packing dimension)

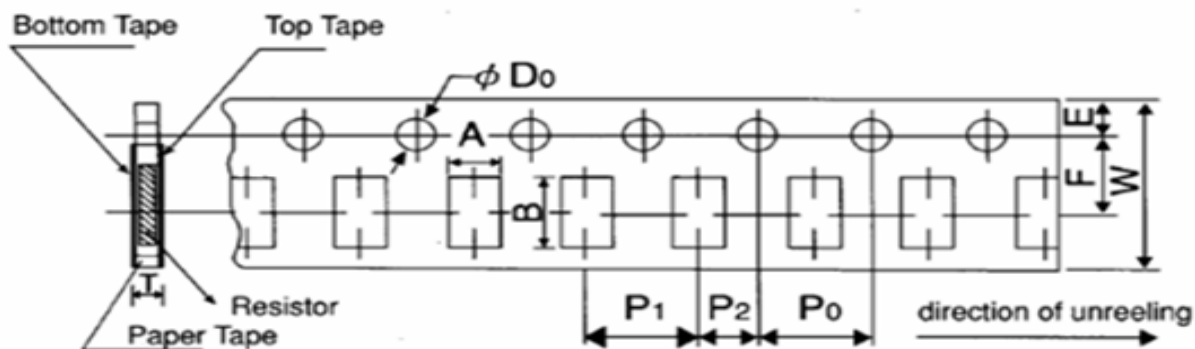

单位:mm

Packing	Type	A	B	W	F	E	P1	P2	P <sub>0</sub>	D <sub>0</sub>	T
Paper Tape	RM1206	2.0±0.15	3.6±0.2	8.0±0.2	3.5±0.05	1.75±0.1	4.0±0.1	2.0±0.05	4.0±0.1	1.50 +0.1/-0	0.84±0.1

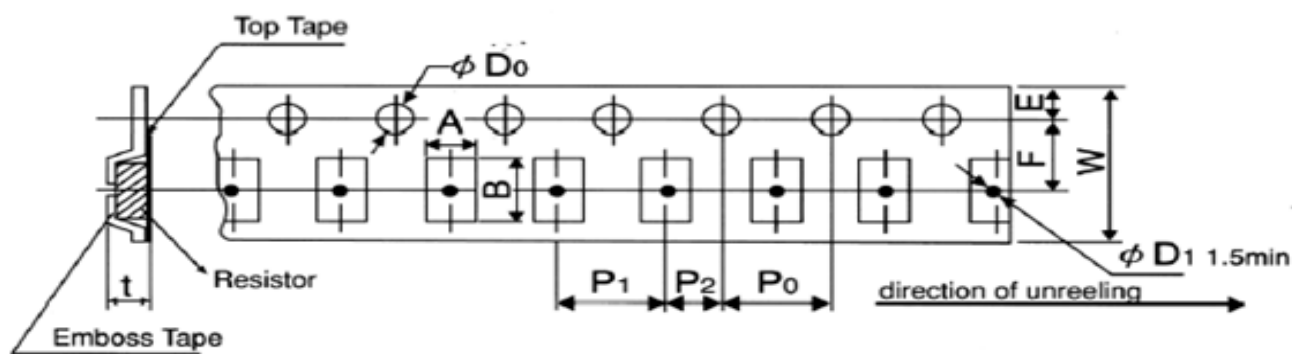

单位:mm

Packing	Type	A	B	W	F	E	P1	P2	P <sub>0</sub>	D <sub>0</sub>	T
Emboss	RM2512	3.6 +0.2/-0.18	6.9±0.2	12.0±0.2	5.5±0.05	1.75±0.1	4.0±0.1	2.0±0.05	4.0±0.05	1.50 +0.1/-0	1.00±0.2

## 合金贴片电阻规格书-RM 系列

### Approval Specification Metal Current Sensing Chip Resistors-Type RM

#### 10 上胶带剥离力测试 (Peel force of top cover tape)

上胶带以 300mm/分钟的速度，沿 165~180 度角的方向进行剥离，如下图所示。纸带的剥离力范围为 0.1N~0.7N(10g~70g)；载带的剥离力范围为 0.3N~1N(30~100g)

The top cover tape is pulled at a speed of 300 mm/min with the angle between the tape during peel and the direction of unreeling maintained at 165 to 180 degree as following picture. The peel force of paper carrier tape shall be 0.1N to 0.7N(10 to 70 g), the peel force of plastic carrier tape shall be 0.3N to 1N (30 to 100 g)

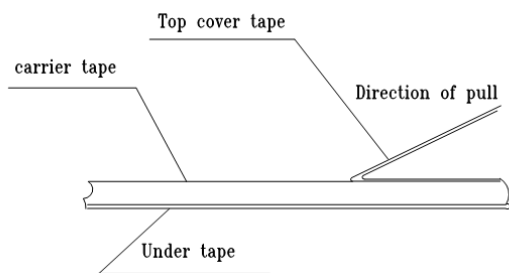

#### 11 焊接 (soldering)

##### a) 建议焊盘尺寸 (Recommended Solder Pad Dimension)

单位:mm

尺寸 Dimensions	阻值范围 Resistance Range	a	b	L
RM1206*T	1mΩ	1.80±0.1	2.30±0.1	1.0±0.1
RM1206*M	2-100mΩ	1.80±0.1	1.70±0.1	1.60±0.1
RM2512*T	1-4 mΩ	4.00±0.1	3.10±0.1	1.80±0.1
RM2512*M	3-300mΩ	4.00±0.1	2.10±0.1	4.10±0.1

## 合金贴片电阻规格书-RM 系列

### Approval Specification Metal Current Sensing Chip Resistors-Type RM

#### b) 建议回流焊曲线 (Recommend reflow soldering profile)

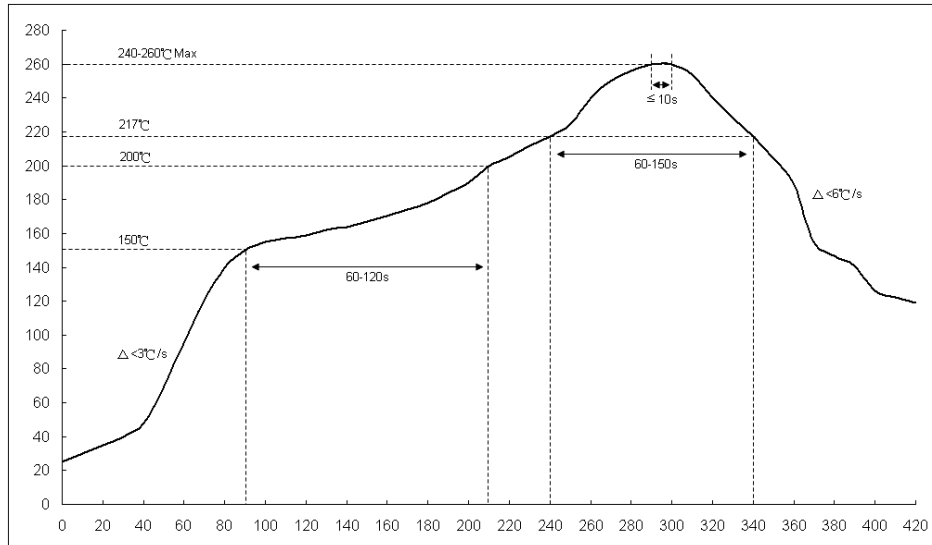

#### c) 建议波峰焊曲线 (Recommend wave soldering profile)

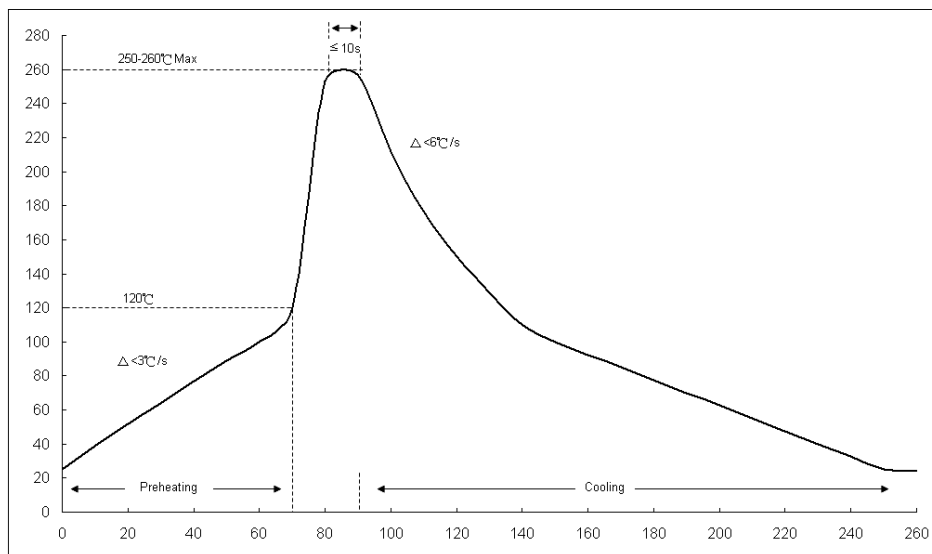

#### d) 手工焊温度 (hand soldering temperature)

烙铁温度  $350 \pm 10^{\circ}\text{C}$ ，3 秒之内，避免烙铁接触电阻本体

The iron temperature is  $350 \pm 10^{\circ}\text{C}$ , hand soldering time less than 3S. Avoid solder iron tip direct touch the components body

★产品规格及资料如有更改,恕不另行通知。

★All product specification and data are subject to change without notice